



TUTHILL
Transport Technologies

Product Bulletin

LOCATIONS

MT. VERNON, MO

Phone:
800-753-0050
Fax:
417-466-3964

BROOKSTON, IN

Phone:
800-255-7824
Fax:
219-279-2390

GRIMSBY

Phone:
800-811-0411
Fax:
905-945-5906

INTERNATIONAL

Phone:
1-417-466-1040
Fax:
1-417-466-1052

We're on the Web
See us at:

reycogranning.com

and

mudhog.com

PRODUCT BULLETIN: PB#B3003

DATE: February 18, 2003
REF: RD975F and RD11KF
SUBJECT: Installation of Air Dump Valves
EFFECTIVE: Immediately

In order to bring the RD975F and RD11KF in line with the rest of the RD series, Tuthill Transport Technologies is removing the air dump valve mounting brackets from the upper air spring mounts.

Bracket being removed

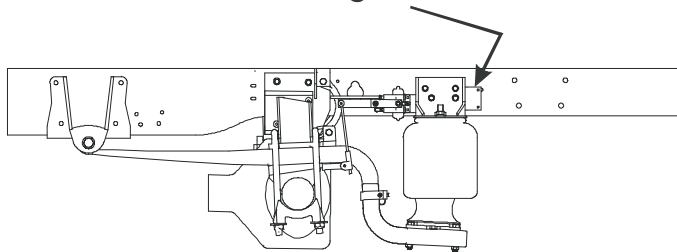

Tuthill recommends mounting the air dump valves inside of the frame rails, utilizing the 8870 bracket. The 8870 bracket is provided with Tuthill supplied air control kits.

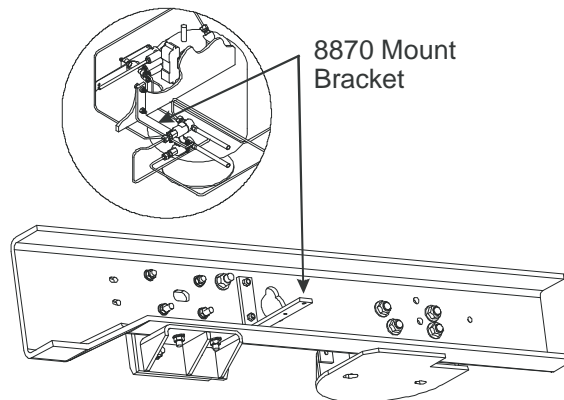

For detailed assistance, please contact your Tuthill Transport Technologies Account Manager at 800-255-7824.



**DOCK
WALK IS
DEAD!**

