

Specification Sheet

R-Series
RD1350F

R-SERIES

AirGlide® RD1350F

drive axle air ride suspension for Ford F550

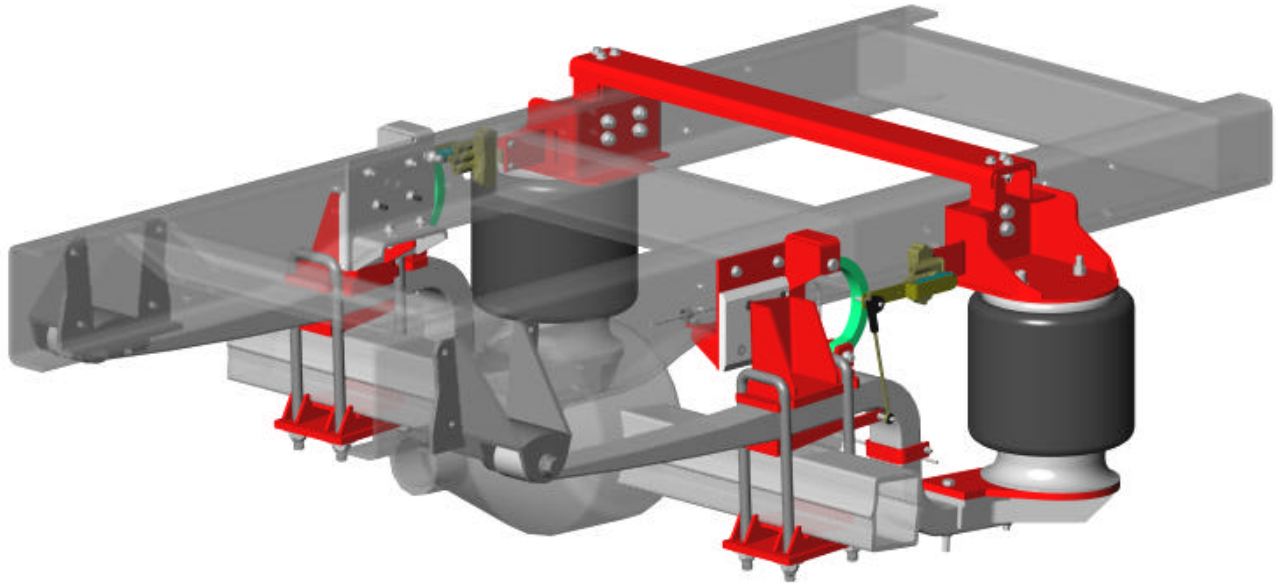

Suspension Capacity Rating

13,500 lbs.

Applications

Ambulances
Shuttle Buses
Trailer Pull Vehicles
Commercial Vehicles

Features and Benefits

- Improved ride over OEM leaf spring suspension.
- Load leveling, front-to-rear and side-to-side.
- Rear "dump" capability.
- Improved roll stiffness..



TUTHILL
Transport Technologies

Brookston, IN USA
Springfield, MO USA
Mt. Vernon, MO USA
Grimsby, ON CAN

Reyco
Granning
SUSPENSIONS

1-800-255-7824

www.tuthill.com

Specification Sheet
R-Series
RD1350F

Ride Height:	Design:	10.19"
	Jounce:	14.04" (3.85" Jounce Travel)
	Rebound:	7.06" (3.13" Rebound Travel)
Suspension Capacity:	13,500 lbs	
Frame Height:	25.19" Ground to Bottom of Frame (Loaded Design, with Air Suspension)	
Vehicle:	Ford F550	
Tires:	225/705R19.5F	
Air Control Kits:	9930, Dual Height Control Valve with Electric Dump Valves 9932, Dual Height Control Valve (no Dump Valves)	
Options:	9905, Auxiliary "Ping" Tank Kit 5703, Low Pressure Warning Kit, includes gauge and buzzer 5895, Gauge Kit 7101, Low Pressure Warning Kit, includes buzzer	

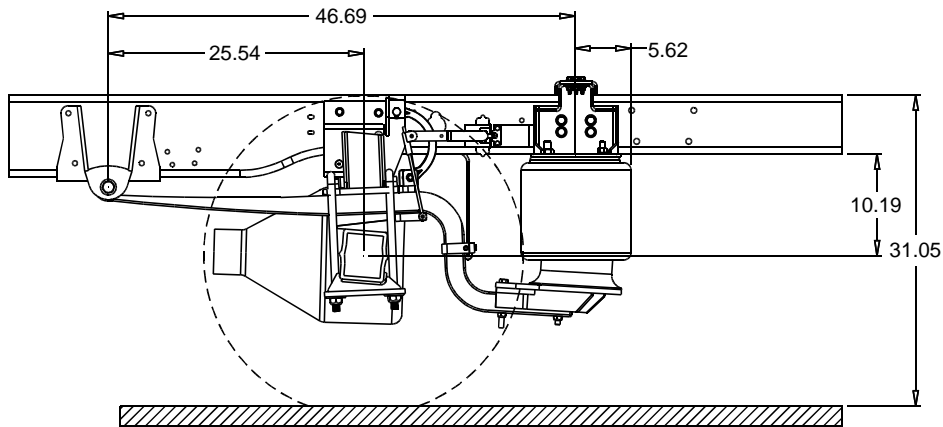
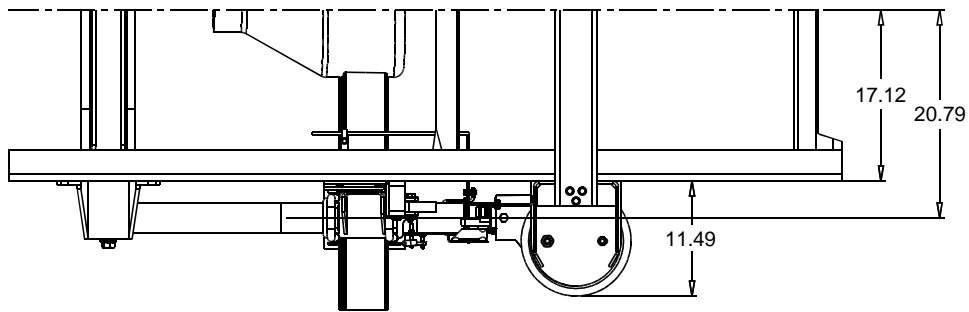

www.tuthill.com

Brookston, IN USA
 Springfield, MO USA
 Mt. Vernon, MO USA
 Grimsby, ON CAN

To place your next ReycoGranning® order or for more information on the specification or installation of a ReycoGranning® suspension, call the customer service number at 1-800-255-7824.

Tuthill Transport Technologies reserves the right to change this information without notice. Information contained herein is general in nature and not intended for specific application purposes.