

Specification Sheet
R-Series
RD1350C

Ride Height:	Design:	8.65"
	Jounce:	5.65" (3.00" Jounce Travel)
	Rebound:	11.65" (3.00" Rebound Travel)
Suspension Capacity:		13,500 lbs
Frame Height:		32.35" Ground to Top of Frame (Loaded Design, with Air Suspension) 29.35" Ground to Top of Frame (Deflated, Jounce Bumper Contact)
Vehicle:		2003 and newer Chevrolet/GMC C4500/5500
Tires:		275/70R19.5
Air Control Kits:		9930, Dual Height Control Valve with Electric Dump Valves 9932, Dual Height Control Valve (no Dump Valves)
Options:		5703, Low Pressure Warning Kit, includes gauge and buzzer 5895, Gauge Kit 7101, Low Pressure Warning Kit, includes buzzer

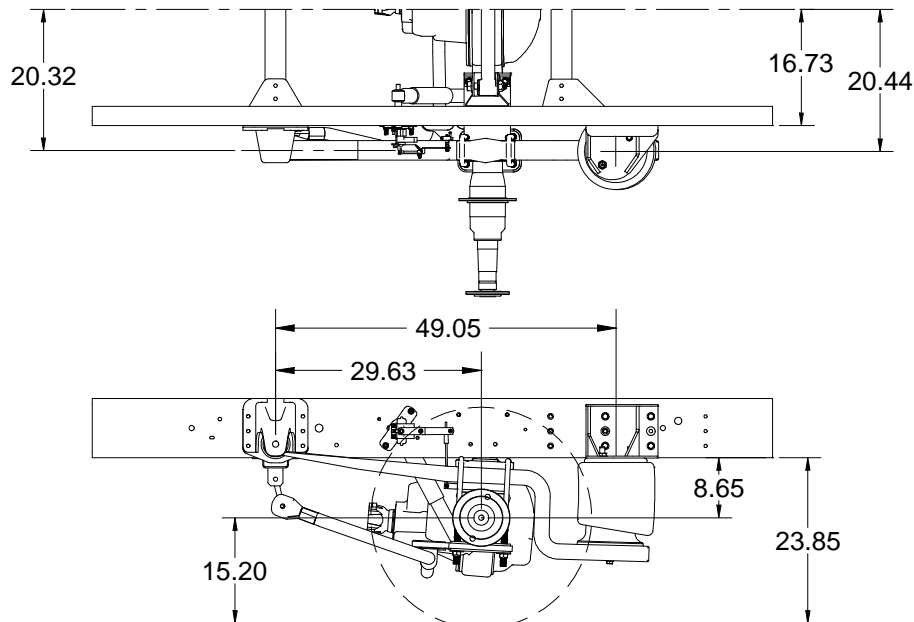

Brookston, IN USA
 Mt. Vernon, MO USA
 Grimsby, ON CAN

To place your next ReycoGranning® order or for more information on the specification or installation of a ReycoGranning® suspension, call the customer service number at 1-800-255-7824.

www.reycogranning.com

Tuthill Transport Technologies reserves the right to change this information without notice. Information contained herein is general in nature and not intended for specific application purposes.

R-SERIES
AirGlide® RD1350C

drive axle air ride suspension for
2003 and newer Chevrolet/GMC C4500/5500

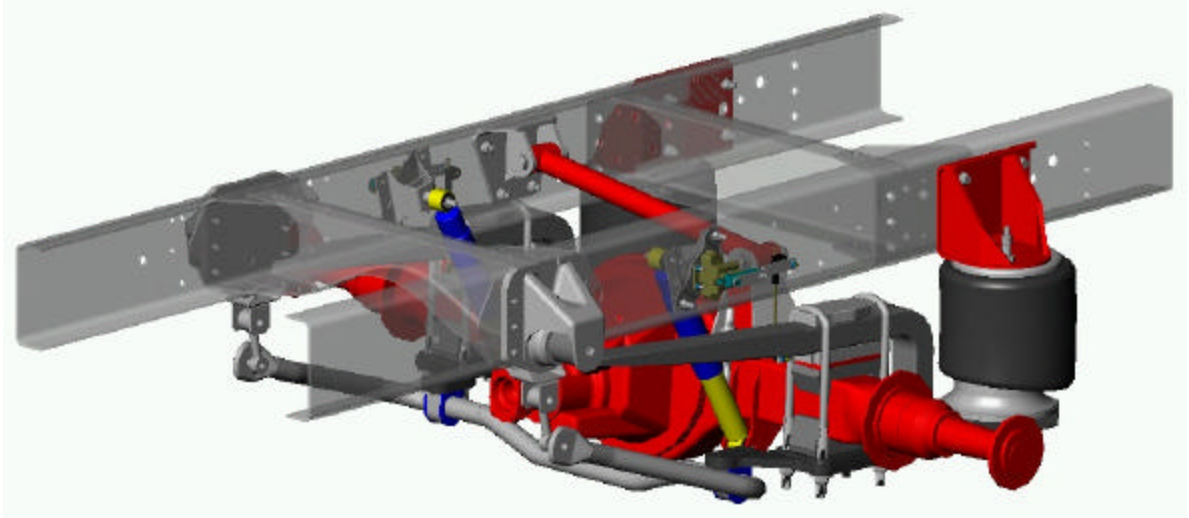

Suspension Capacity Rating

13,500 lbs.

Applications

Ambulances
Shuttle Buses
Trailer Pull Vehicles
Commercial Vehicles

Features and Benefits

- Improved ride over OEM leaf spring suspension.
- Load leveling, front-to-rear and side-to-side.
- Rear "dump" capability.
- Improved roll stiffness..



TUTHILL
Transport Technologies

Brookston, IN USA
Mt. Vernon, MO USA
Grimsby, ON CAN

Reyco
Granning
SUSPENSIONS

1-800-255-7824
www.reycogranning.com