

Reyco Granning

S U S P E N S I O N S

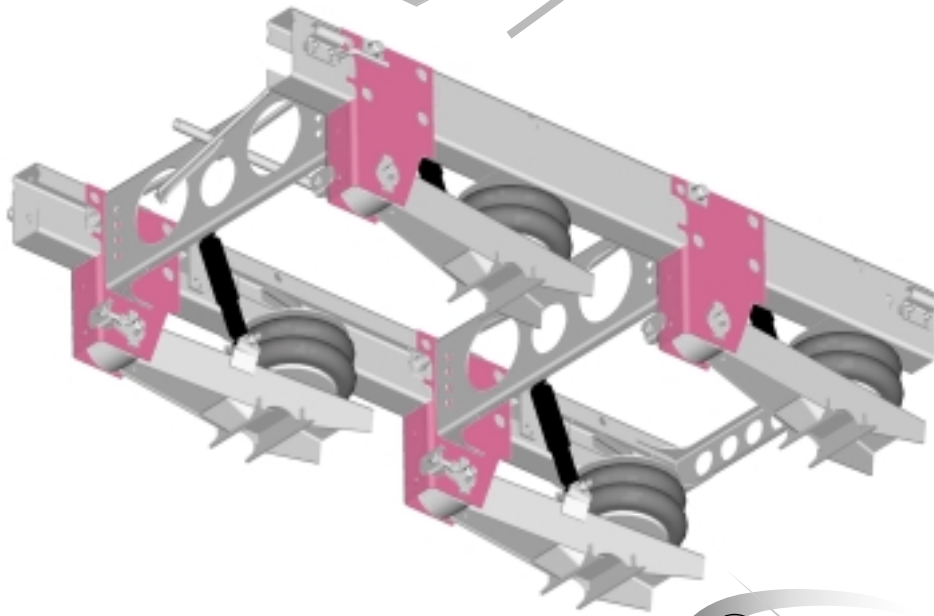

19AR/RS1062 SLIDER SYSTEM

FEATURES

- Unitized hanger and strong rail eliminate buckling due to curbing
- 9" slider rails (7 gauge) provide superior strength with no weight penalty
- 4-1/2" multi-function pivot bushing
- Rey-Align® - "True" one-person multiple alignment system
- FLEXI-PULL eliminates strain and frustration of retracting slider pins
- Plugwelds used in hangers to reduce stress risers

BENEFITS

- Quick recover back to ride height
- Optimum stability and roll rates
- Single source purchasing
- 40,000 lbs. capacity
- Axle stress reduced to a minimum
- No u-bolts
- Pneumatic pin release system available
- Anti dock walk system (LOADBLOCK) available
- Mud flap brackets available



Dare to Compare. Less Weight. More Freight.

ITEM	DESCRIPTION	WEIGHT	RIDE HEIGHT	SLIDER WIDTH	BODY RAIL STYLE	AXLE TRACK
702019-01	RS1062 Slider w/ Load Block w/ 19AR suspension	937	14	48.46	Hutch	77.5
702019-02	RS1062 Slider w/ Load Block w/ 19AR suspension	936	14	48.38	TTMA	77.5
702019-03	RS1062 Slider w/ Load Block w/ 19AR suspension	933	14	48	Binkley	77.5
702019-04	RS1062 Slider w/ Load Block w/ 19AR suspension	940	15	48.46	Hutch	77.5
702019-05	RS1062 Slider w/ Load Block w/ 19AR suspension	939	15	48.38	TTMA	77.5
702019-06	RS1062 Slider w/ Load Block w/ 19AR suspension	936	15	48	Binkley	77.5
702019-07	RS1062 Slider w/ Load Block w/ 19AR suspension	963	16	48.46	Hutch	77.5
702019-08	RS1062 Slider w/ Load Block w/ 19AR suspension	962	16	48.38	TTMA	77.5
702019-09	RS1062 Slider w/ Load Block w/ 19AR suspension	959	16	48	Binkley	77.5
702019-10	RS1062 Slider w/ Load Block w/ 19AR suspension	968	17	48.46	Hutch	77.5
702019-11	RS1062 Slider w/ Load Block w/ 19AR suspension	967	17	48.38	TTMA	77.5
702019-12	RS1062 Slider w/ Load Block w/ 19AR suspension	964	17	48	Binkley	77.5
702019-101	RS1062 Slider w/ Load Block w/ 19AR suspension w/PPRS	947	14	48.46	Hutch	77.5
702019-102	RS1062 Slider w/ Load Block w/ 19AR suspension w/PPRS	946	14	48.38	TTMA	77.5
702019-103	RS1062 Slider w/ Load Block w/ 19AR suspension w/PPRS	943	14	48	Binkley	77.5
702019-104	RS1062 Slider w/ Load Block w/ 19AR suspension w/PPRS	950	15	48.46	Hutch	77.5
702019-105	RS1062 Slider w/ Load Block w/ 19AR suspension w/PPRS	949	15	48.38	TTMA	77.5
702019-106	RS1062 Slider w/ Load Block w/ 19AR suspension w/PPRS	946	15	48	Binkley	77.5
702019-107	RS1062 Slider w/ Load Block w/ 19AR suspension w/PPRS	973	16	48.46	Hutch	77.5
702019-108	RS1062 Slider w/ Load Block w/ 19AR suspension w/PPRS	972	16	48.38	TTMA	77.5
702019-109	RS1062 Slider w/ Load Block w/ 19AR suspension w/PPRS	969	16	48	Binkley	77.5
702019-110	RS1062 Slider w/ Load Block w/ 19AR suspension w/PPRS	978	17	48.46	Hutch	77.5
702019-111	RS1062 Slider w/ Load Block w/ 19AR suspension w/PPRS	977	17	48.38	TTMA	77.5
702019-112	RS1062 Slider w/ Load Block w/ 19AR suspension w/PPRS	974	17	48	Binkley	77.5

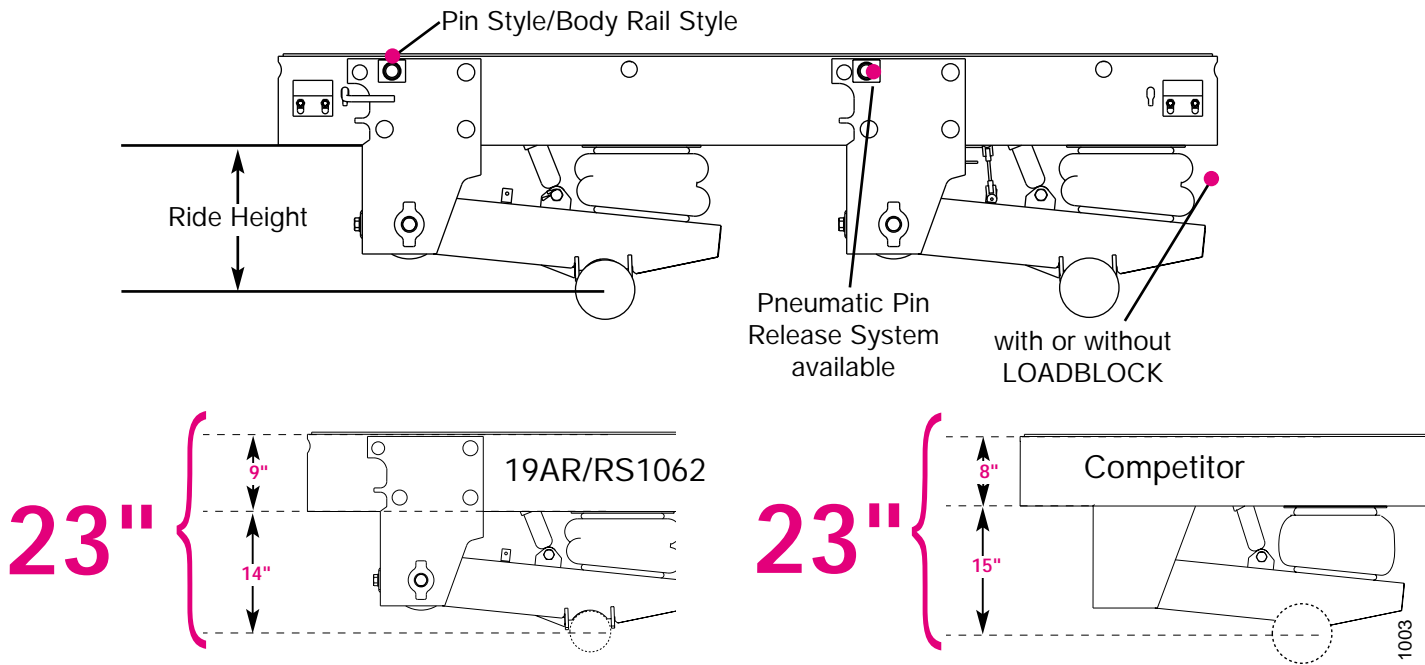

Strong Slider Rails. No Weight Penalty.



GRIMSBY (CANADA) 1.800.811.4011 Fax: 1.905.945.5906
 MT. VERNON (USA) 1.800.753.0050 Fax: 1.417.466.3964
 BROOKSTON (USA) 1.800.255.7824 Fax: 1.219.279.2390

www.reycogranning.com



Form #19AR/RS1062 TEARSHEET rev. 1003